



Creating Intelligent Cyberinfrastructure for Democratizing AI: Overview of the Activities at the NSF-AI Institute ICICLE

Keynote Talk at Workshop on Indo-USA Initiatives (@HiPC '23)

by

<http://icicle.ai>

Dhabaleswar K. (DK) Panda

The Ohio State University

E-mail: panda@cse.ohio-state.edu

<http://www.cse.ohio-state.edu/~panda>



Follow us
@icicleai

Credits to all ICICLE Team Members!!



ICICLE Members
Attending
All-Hands-Meeting
In-Person
(Nov '23)

Outline

- **ICICLE Vision and Goals**
- Research Challenges Addressed
- Highlights of Selected Accomplishments
- How to Get Engaged?
- Conclusions

Computing has been evolving over the last three decades with multiple **phases**:

- Phase 1 (1975-): Scientific Computing/HPC
- Phase 2 (2000-): HPC + Big Data Analytics
- Phase 3: (2010-): HPC + AI (Machine Learning/Deep Learning)

Emergence of the Computing Continuum

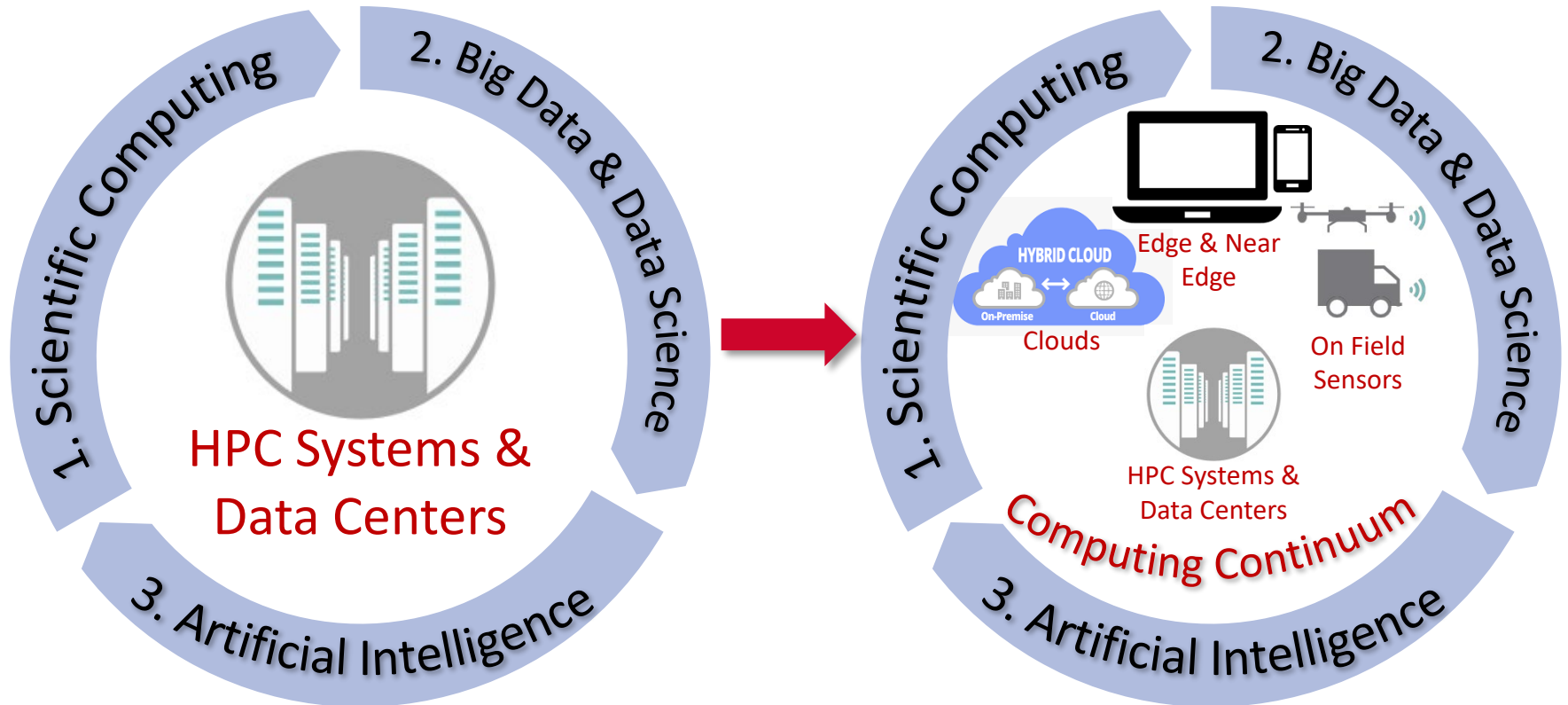

Societal Challenge (Example #1): Agriculture

- **Food security/sustainability in 2050**
 - 9.8B people, climate; 0.5x arable land per cap vs 1985
 - Wide gains in crop management needed (typical yields fall 3X below best practice)
- **Sustainable agricultural workforce**
 - The next generation of agriculture professionals will include engineers, computer scientists, data scientists
- **Democratization of digital agriculture capabilities**
 - Autonomous unmanned aerial vehicles, self-driving tractors and sprayers, fertilizer and seed recommendations
 - Big and small farms, staple and specialty crops, underrepresented communities
 - Privacy and ethical considerations

AI-Driven Digital Agriculture

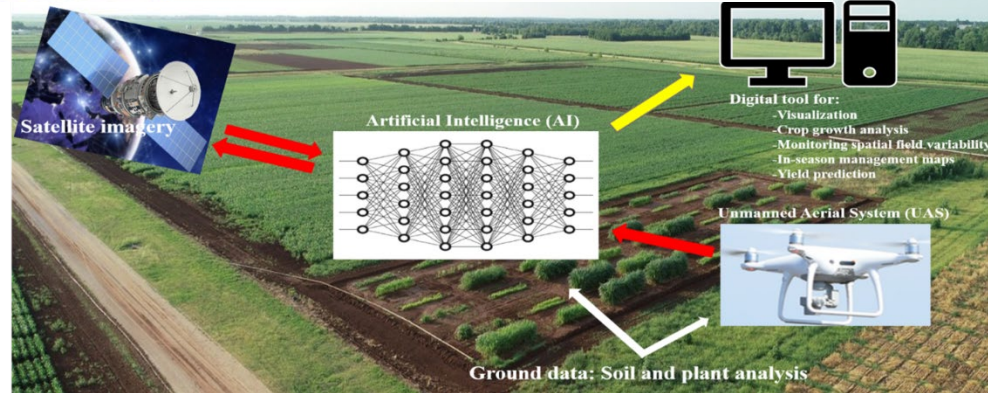

Challenges in Designing AI-Driven CI for Digital Agriculture in Computing Continuum

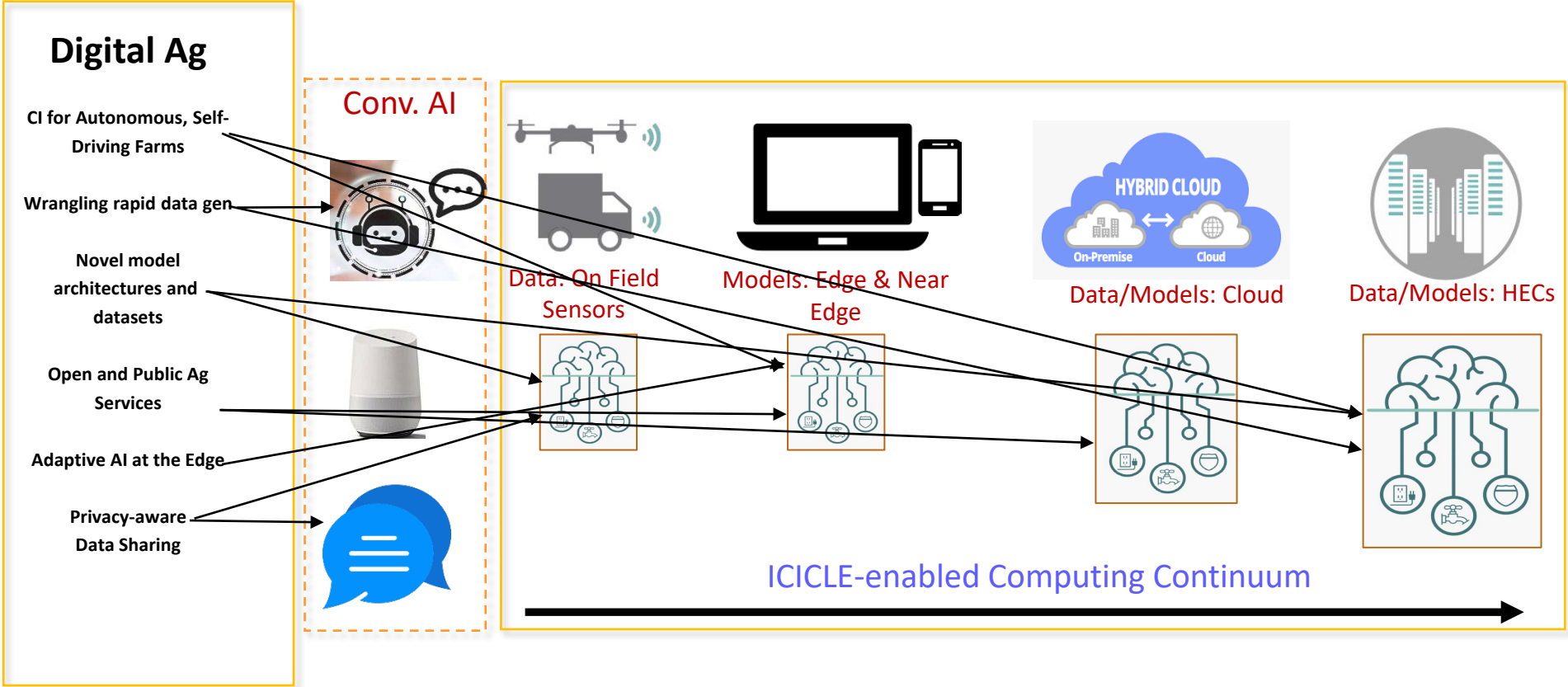

Societal Challenge (Example #2): Animal Ecology

- **Basic science:** The focus of Animal Ecology is understanding the functioning and behavior of animals individually and in groups *in the context of environment* and evolution.
- **Science + translational:**
 - Monitoring, understanding, and protecting biodiversity of the planet
 - Monitoring and understanding the impact of changing habitats on animals that live in them
- **Translational:** biodiversity conservation and mitigating the impact of climate change

Challenges in Designing AI-Driven CI for Animal Ecology in Computing Continuum

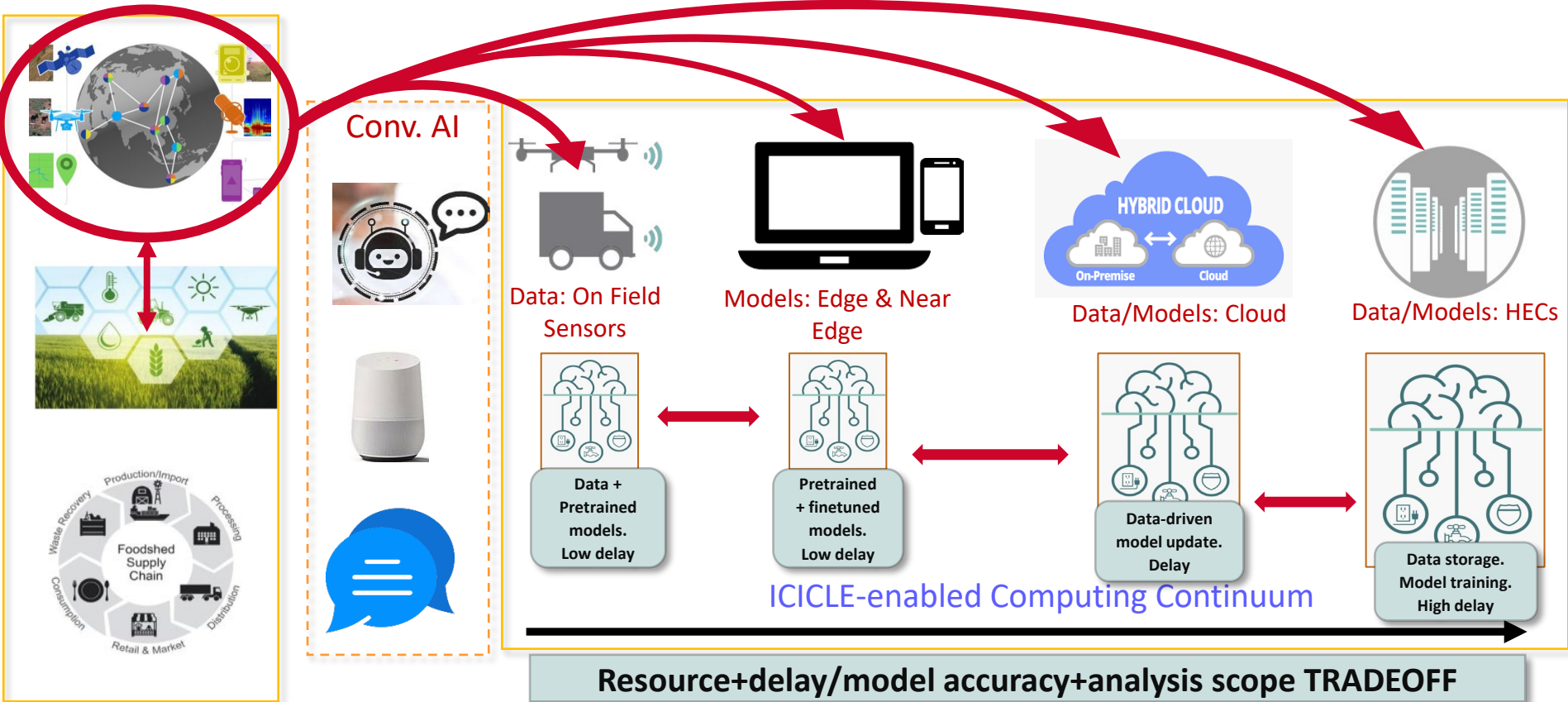

Societal Challenge (Example #3): Smart Foodsheds

- **Food Supply Chain Vulnerabilities**
 - Concentration contributes to bottlenecks, lack of resilience to disruptions
- **High Food Insecurity**
 - Supply chain decisions fail to account for impacts on food access, cost, availability
- **Food Waste**
 - Inefficiencies in food supply chains and food systems lead to 30-40% waste
- **Negative Environmental Footprint**
 - Farming and food system has major impacts on environment
- **Holistic Food Systems Planning is Difficult**
 - Data is difficult to access, not coordinated across sectors or food supply chain actors

AI-Driven Foodshed Supply Chain Management?



Which food supply chains will likely be affected by an approaching storm?

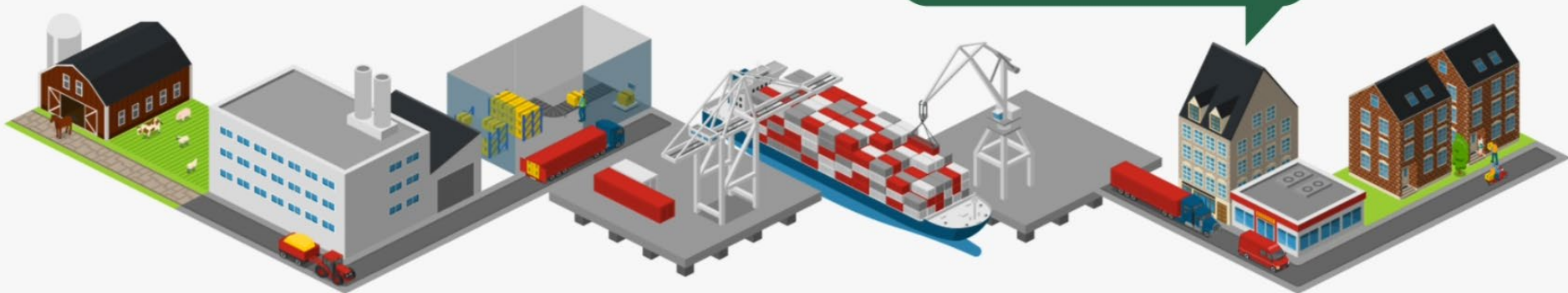

Farm —> Manufacturing —> Packaging —> Transportation —> Distribution —> Market —> Consumer

Challenges in Designing AI-Driven CI for Smart Foodsheds in Computing Continuum

Smart Foodsheds

Diverse data sources
database federation

Heterogenous food systems and actors

Conversation agents and knowledge graph

Food system planning

Easy-to-use

intelligent visual analytics



Conv. AI

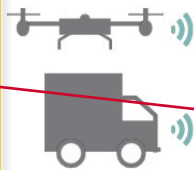

Data: On Field Sensors



Models: Edge & Near Edge

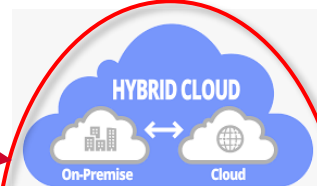

Data/Models: Cloud



Data/Models: HECs

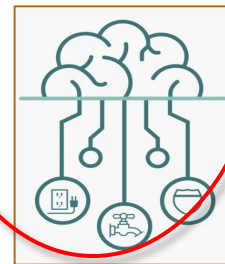

ICICLE-enabled Computing Continuum



How AI can Help the Users of these Science Cases?

For the three use-inspired science cases:

- Massive and ever-growing gap between AI and its accessibility to the users
- Existing AI applications are developed largely ad-hoc and lack coherent, standardized, modular, and reusable infrastructure
- Successful AI solution(s) for one use case rarely generalize to other use cases, or even the same use case even with slightly different context.

CI's complexity to deploy AI impedes research discoveries and innovations!

Many more examples

- Smart Cities
- Smart Manufacturing
- Smart Transportation
- Real-time Surveillance
- Computational Medicine (Pathology, Radiology, ..)

Broad Challenge

Designing the next-generation **intelligent cyberinfrastructure** for a **computing continuum with heterogenous resources** that is usable in a **plug-and-play** manner by **stakeholders** to solve **societal challenges?**

The ICICLE Overview Video

The Video is available from

<https://youtu.be/gNFk5tDTtoU>

The Vision

A **national infrastructure** that will:

- Catalyze **foundational AI/CI** and transform application domains
- **Democratize AI** through **integrated plug-and-play AI**
- **Transparent and trustworthy** infrastructure for AI-enabled future
- Address **societal problems** (agriculture, conservation, food insecurity) **globally**
- Grow **new generations of workforce** and incubate **sustainable and inclusive** communities

Objectives: Intelligent CyberInfrastructure for Computing Continuum

Use Inspired Science Domains



Digital
Agriculture



Smart
Foodsheds



Animal
Ecology

ICICLE: Intelligent CyberInfrastructure with Computational Learning in the Environment

Systems AI Foundational Research for CI

Intelligent Cyber Infrastructure

CI for AI

AI for "CI for AI"



On Field
Sensors



Edge & Near Edge

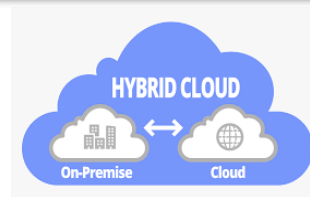

Clouds



HPC Systems & Data
Centers

Emerging Computing Continuum

ICICLE As A Whole

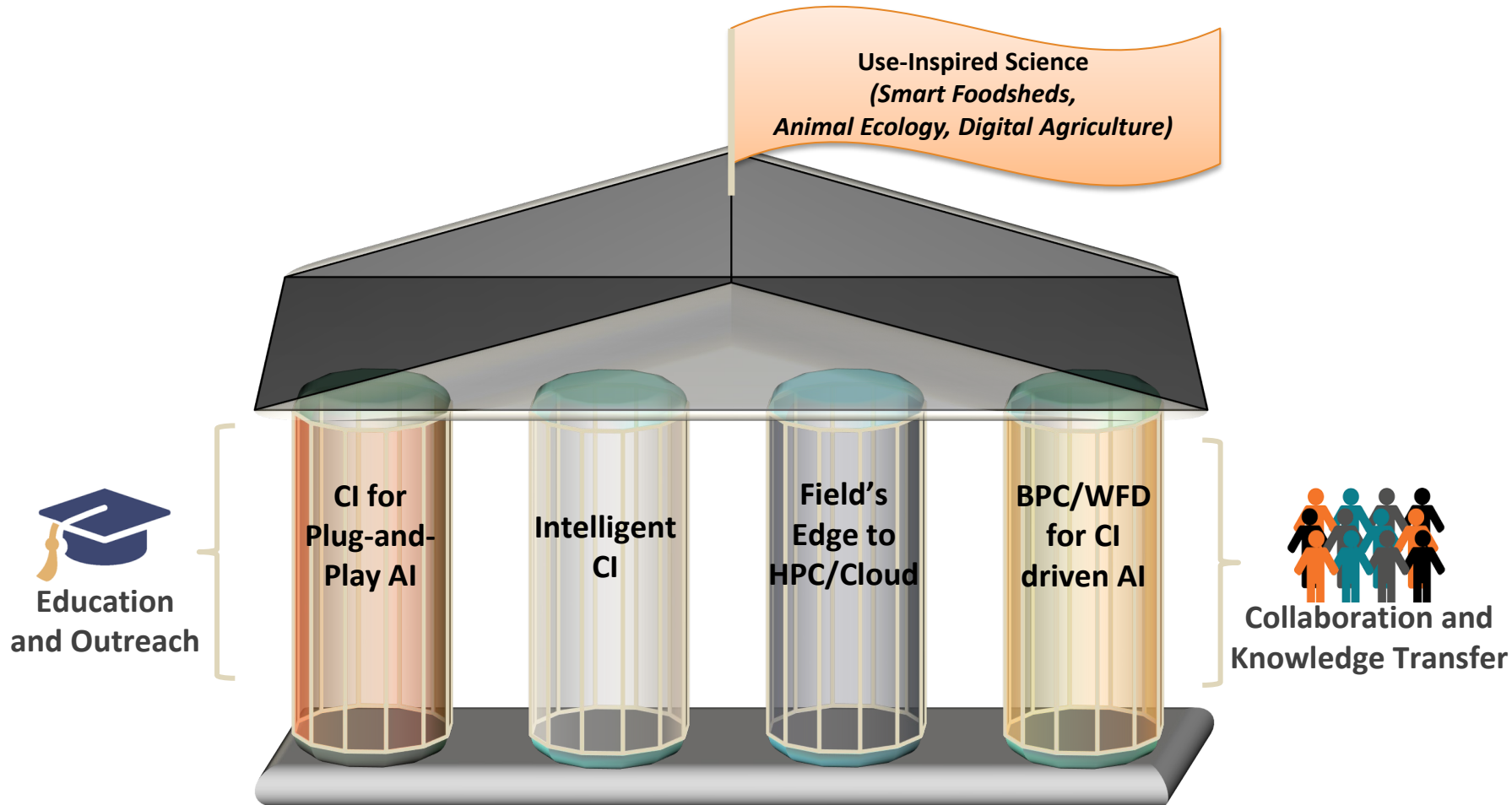

Participation:

14 Organizations, 33 faculty, 41 staff, (58 PhD, 16 MS, 16 undergrad, 6 K-12) students & many Collaborators



Govt. Agencies & National Labs



Research Institutes



International



Industry



NSF AI Institutes



Hospitals & Universities



Collaboration: ICICLE and the Technology Innovation Hub (TIH) at the Indian Institute of Technology Bombay (IIT-B), India

Digital Agriculture



This research collaboration will contribute novel design paradigms for context-adaptive CI and aims to develop next-generation CI for *Digital Agriculture* including AI and machine learning methods targeting 3 core areas.

Crop Health Modeling



- Sense crop health and level context to predict crop yield
- Detect stressors and diseases for geographically diverse crops
- Apply remedies with little human intervention via Internet of Things (IoT) and sensor systems

Privacy-Preserving Data Exchange

Create secure, trustworthy, and privacy-preserving platforms that connect farmers and allow them to share information and resources safely.

Aerial Crop Scouting



- CI for fully autonomous aerial systems
- Simplify deployment of UAV in real fields to capture common crop health conditions
- Provide accurate maps that yield valuable insights for crop management

Building upon the existing ICICLE infrastructure, CI and AI capabilities, researchers will leverage contextual conditions in India for *Digital Agriculture* that differ from the United States to (1) expose brittle CI components, (2) make AI4CI more robust and expansive in the long-term, (3) devise principles that yield context-aware CI

Timeline

- Started on Nov 1, 2021
- Finished two years of the project, Starting Yr3

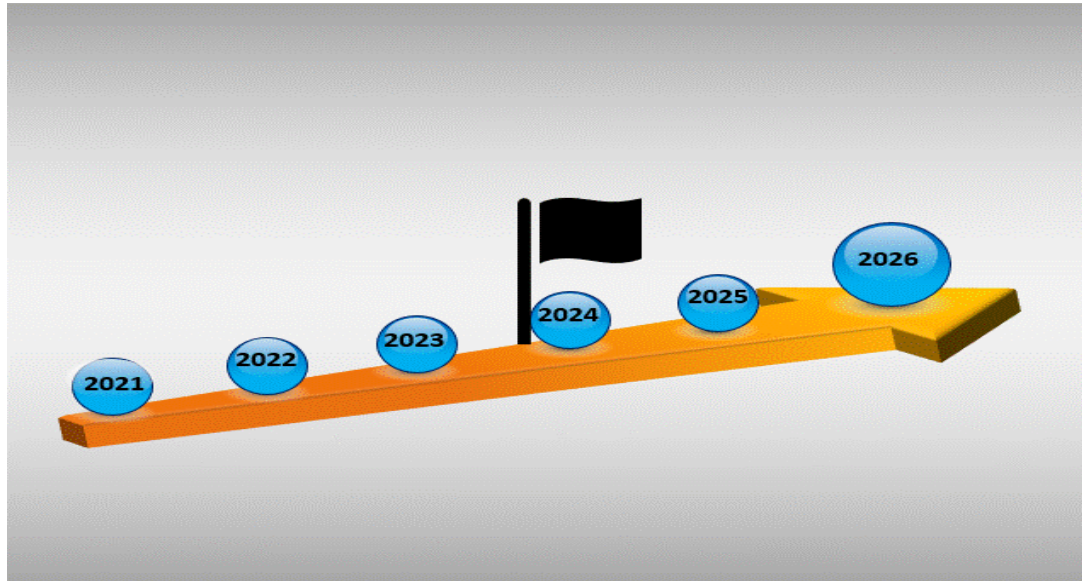

Outline

- ICICLE Vision and Goals
- **Research Challenges being Addressed**
- Selected Accomplishment Highlights
- How to Get Engaged?
- Conclusions

Research Plan: Overall Vision

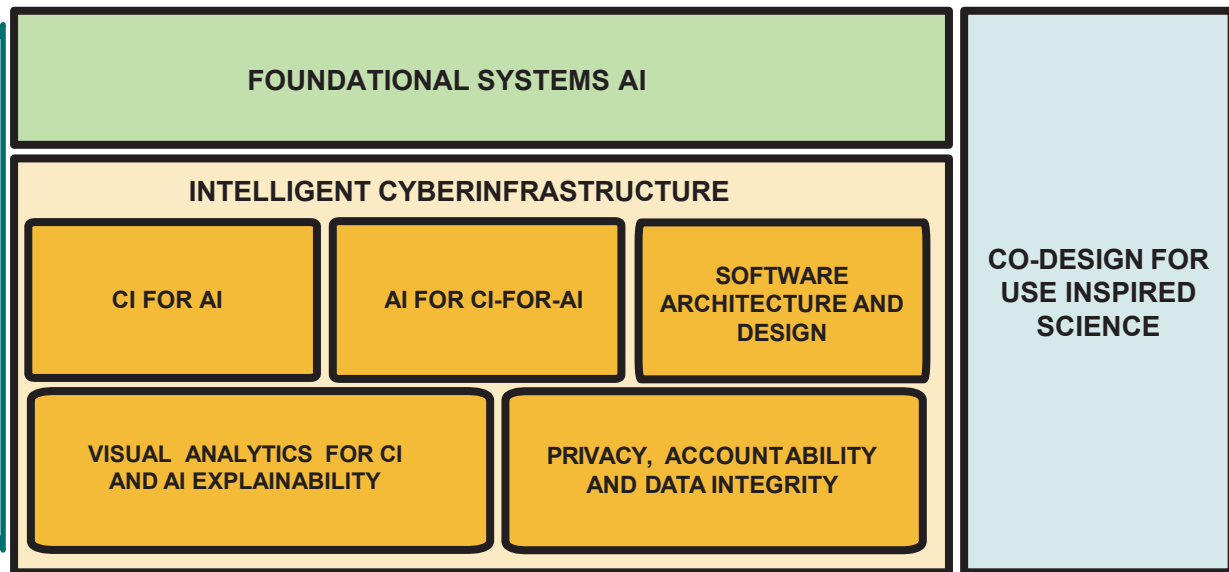
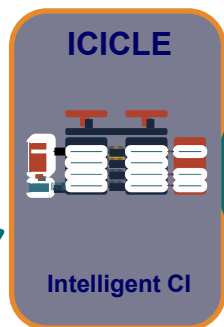

Thrust: Foundational Systems AI

Components address CI complexity and heterogeneity for plug-and-play

Knowledge Graphs

- Multimodal KG to encode & reason rich data modalities (e.g., camera trap)
- Auto construction
- Interplay with LLM and knowledge-based QA

Model Commons

- MINT to support ICICLE use cases, KG, and models
- Precise profiling
- Flex composition
- Versioning and provenance

Adaptive AI

- Context-aware
- Efficient update
- User-friendly adaptation process
- Adaptation of foundation models, conversational AI

Federated Learning

- Heterogeneity
- Context-aware
- Privacy-preserving and robustness
- Going beyond classification (GNN, foundation models)

Conversational AI

- KG- and model-commons-aware
- LLM-powered
- Grounding LLMs to the context
- Hallucination reduction
- Complex reasoning

Thrust: CI4AI

Provides necessary CI to deploy AI throughout computing continuum and make it plug-and-play!

High Perf. Training

- High-performance communication libraries
- Gradient sparsification
- Exploiting data-, model-, pipeline-, and hybrid-parallel paradigms

High Perf. Data Management

- Unified storage of data, model and hyperparameters
- Data location transparency with migration
- Leveraging new hardware

Edge Intelligence

- Performance characterization of edge
- Optimize ML/DL inference on edge devices
- Profiling edge devices to improve quality of service

AI-Adaptive Edge Wireless

- High-throughput, reliable communications
- Predictable Wireless Comm. via Rateless-Coding & Multi-Modal/Path
- AI-adaptive edge wireless prototypes.

Control and Coordination

- Functional/Performance Interface Design
- Intelligent Resource Management with Tapis
- Hardening and Optimizing for Production-ready Service

Thrust: AI4CI

Enhances CI with AI for adaptive and field-optimized machine learning!

**KGs & Model
Commons for CI**

- Investigate and survey existing datasets for CI optimization
- Create new CI components to serve CI data and models for other ICICLE CI and AI4CI components
- Edge-specific CI dataset distributed as KGs

**Intelligent Modeling
and Optimization**

- Collection of baseline performance
- Exploration of analytical metrics
- Use and refinement of hybrid models in a design-space explorer for code optimization

Applications

- Application Selection and Performance Profiling
- Building Performance Models
- Designing Features for Applications, Frameworks, and Hardware

Middleware

- Develop a set of intelligent linear algebra kernels for sparse-matrix operations
- Leverage data sparsity in all computational kernels.
- Cross-layer Optimizations

Systems

- Resource allocation optimizer for ML training
- Develop an optimizing middleware for ML inference placement based on our use cases.
- Intelligent Wireless Communications

Thrust: Privacy, Accountability and Data Integrity (PADI)

- PADI contributes to
 - ICICLE vision as *transparent and trustworthy* infrastructure for AI-enabled future
 - An ethically aligned infrastructure and workforce through an *AI ethics framework*
- PADI advances both technical and non-technical innovations and best practices that collectively contribute to a trusted environment
 - e.g., where stakeholders (farmers, industry partners, etc.) are comfortable contributing data and AI models for ICICLE AI research (and more broadly for AI research).
- PADI addresses both research questions and issues of practice (project norms and practice)

Thrust: Visual Analytics

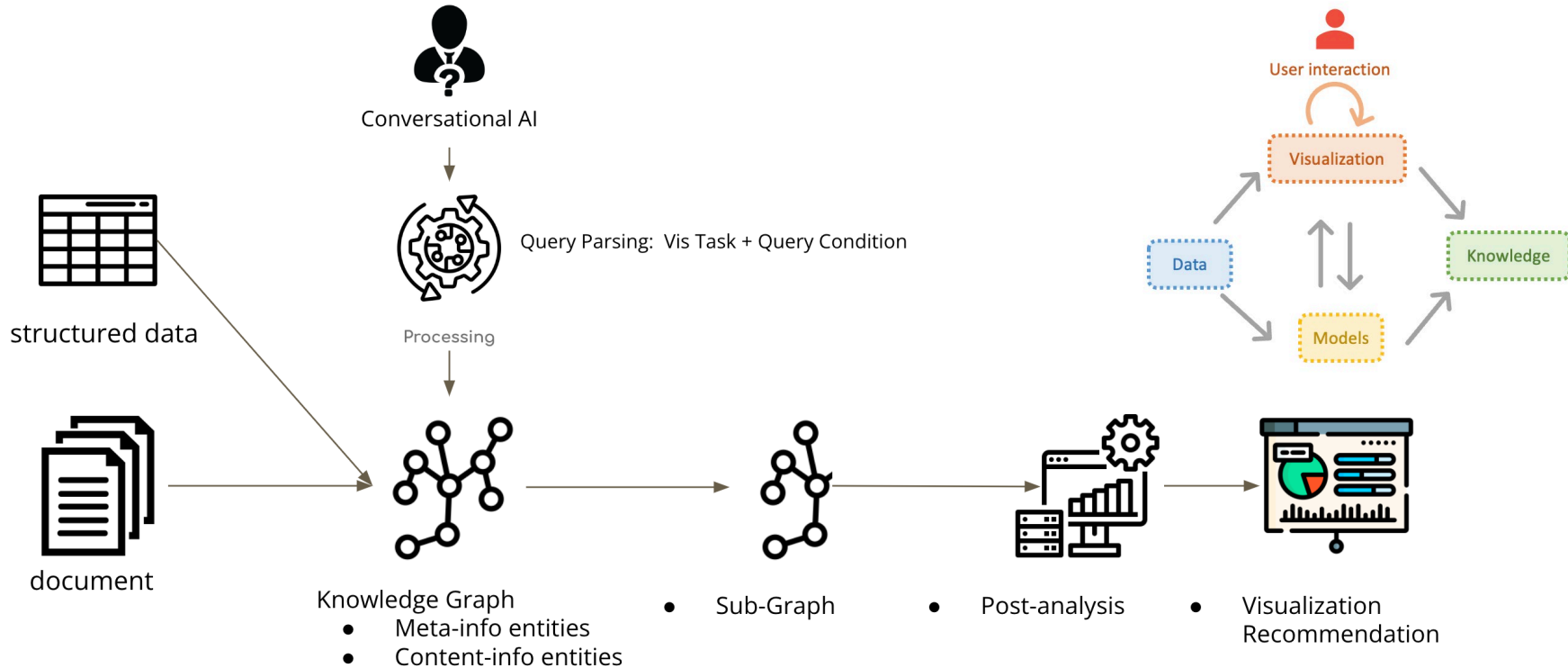

Co-Designing with use-inspired domains

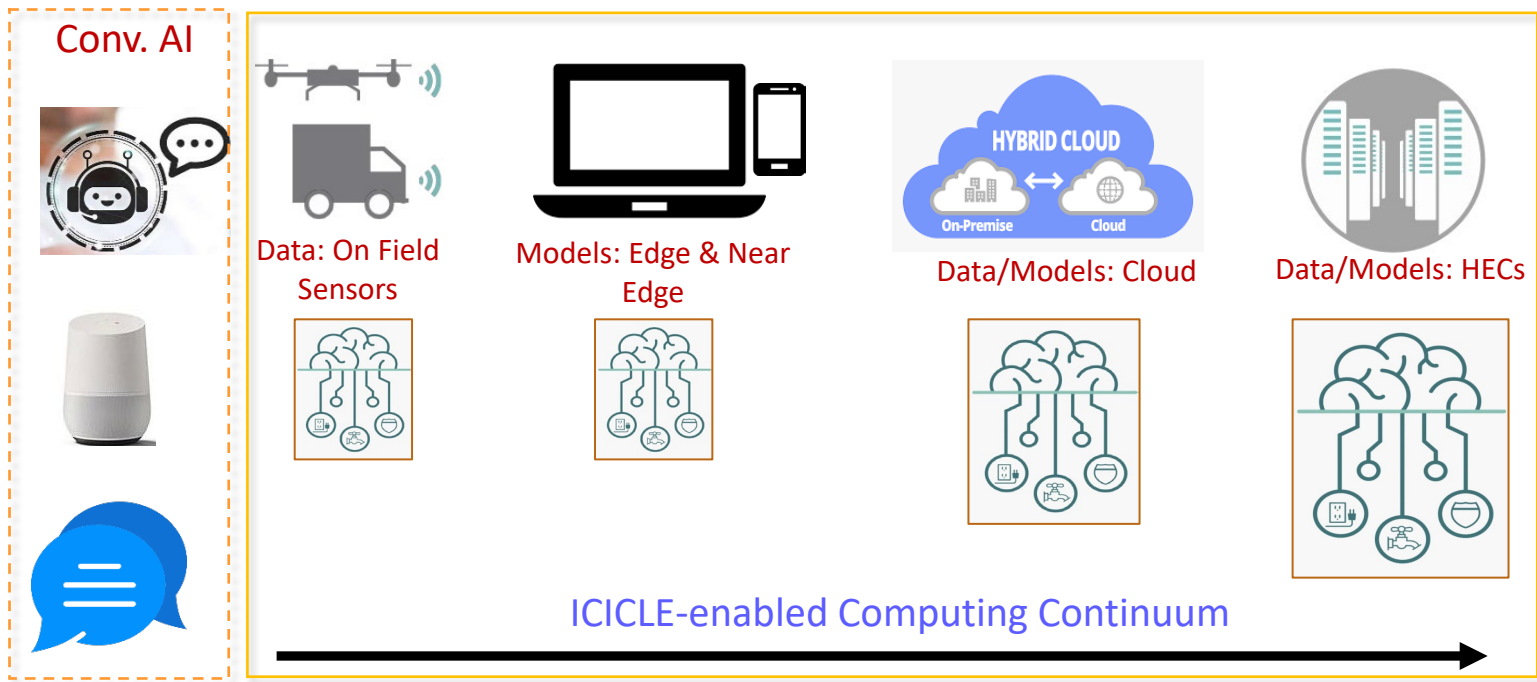

The Deliverable: The ICICLE Software Stack



RESEARCHERS & USERS IN THE FIELD



END USER APPLICATIONS

CONVERSATIONAL AI

DATA VISUALIZATION

INTERACTIVE NOTEBOOKS, CLI,
SDK, WEB APP

WORKER
AGENTS

DATA
TRANSFER

RESOURCE
PROVISIONING

JOB
SCHEDULING

NOSQL

MESSAGE BROKER

SQL

PERSISTENCE

SYSTEMS &
FILES

STREAMS

META

APPS &
FUNCTIONS

JOBS

KNOWLEDGE
GRAPHS

CONVERSATIONAL AI

MODEL
COMMONS

HISTORY &
PROVENANCE

AUTHN &
AUTHZ

HTTP FRONT END APIS

FILE
SYSTEMS

AI DATABASES

GIT REPOSITORIES

CONTAINER
REGISTRIES

EXECUTION
HOSTS

HPC &
CLOUD
DATA
CENTERS

EDGE & NEAR EDGE

FIELD SENSORS

MODELS

CONTROLLER

ICICLE GATEWAY

MODELS

DATA



Broader Impacts Backbone Network (BIBN)

BIBN is a consortium with the goal of democratizing AI!

Oversees activities towards broader impacts and engagement:

- Diversity Equity and Inclusion (DEI)
- Broaden Participation in Computing (BPC)
- Workforce Development (WFD)
- Collaboration and Knowledge Transfer (CKT)

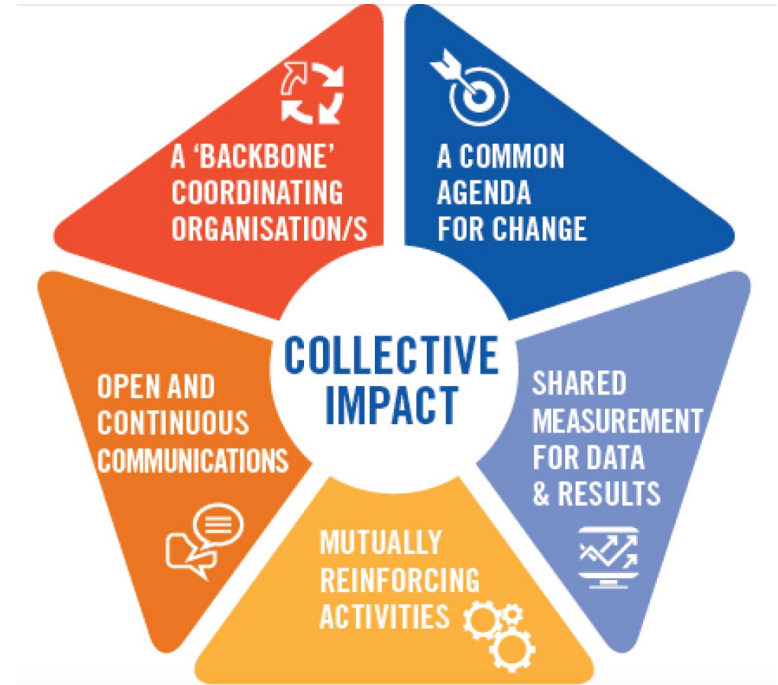

Outline

- ICICLE Vision and Goals
- Research Challenges being Addressed
- **Selected Accomplishment Highlights**
 - **CI/Software Released**
 - **Digital Agriculture (demo)**
 - **Smart Foodsheds (demo)**
 - **Grocery Store Closure (demo)**
 - **AI4CI**
 - **BIBN**
- How to Get Engaged?
- Conclusions

CI/Software Components Released (so far)

2023.04 Release (04/30/23)

- **AI4CI**
 - HPC Application Runtime Predictor (HARP) v1.0
 - Intelligent Sparse Library (iSpLib) v1.0
- **Software and Reference Architecture**
 - Base ICICLE Tapis Software v1.3.0
 - Event Engine v0.2.0
 - Hello ICICLE Authentication Clients v0.0.1
 - Tapis Pods Service v1.3.0
 - CI Components Catalog v0.1.0
- **Animal Ecology**
 - Camera-Traps Edge Simulator v0.3.0
- **Digital Agriculture**
 - SoftwarePilot v1.2.5
- **Smart Foodsheds**
 - Persons-Projects-Organizations-Datasets (PPOD) Schema v0.9.1
 - Smart Foodsheds Visual Analytics (VA) Dashboard v0.1

2023.06 Release (06/30/23)

- **AI Foundations**
 - ICICLE Foodshed Parser v0.1
 - Species Classification using Multimodal Heterogeneous Context v0.1.0
 - Region2vec v1.0
- **Software and Reference Architecture**
 - Tapis Federated Authentication Service v1.3.4
 - ICICONSOLE v0.0.10
 - TapisCL-ICICLE v0.1.4
 - Tapis Pods Service v1.3.2
- **Animal Ecology**
 - Camera-Traps Edge Simulator v0.3.1
- **Digital Agriculture**
 - ICICLE Digital Agriculture Hub v1.0
 - Far-Edge Edge Simulator v1.0
 - In-Field Helper for Crop Scouts v1.0
- **Smart Foodsheds**
 - Persons-Projects-Organizations-Datasets_California (PPOD_CA) Knowledge Graph v23.06
 - Kroger Store Closure v0.1
 - Smart Foodsheds Visual Analytics (VA) Dashboard v0.2

<https://icicle.osu.edu/cyberinfrastructure/software>

CI/Software Components Released (so far)

2023.10 Release (10/06/23)

- **AI4CI**
 - HPC Application Runtime Predictor (HARP) v2.0
 - High Performance Computing Applications Dataset v1.0
- **Software and Reference Architecture**
 - iciflaskn v1.0
 - ICICONSOLE v0.8.0
 - TapisCL-ICICLE v1.0.11
- **Animal Ecology**
 - Camera-Traps Edge Simulator v0.3.2
- **Smart Foodsheds**
 - Smart Foodsheds Visual Analytics (VA) Dashboard v0.3

<https://icicle.osu.edu/cyberinfrastructure/software>

Digital Agriculture



What does CI for digital agriculture look like?



How to build CI that connects a wide range of digital agriculture stakeholders?



Why use-inspired CI will be transformative?

ICICLE Use-Inspired Science: Digital Agriculture



Scott Shearer
Food, Agriculture and Biological Eng.

Christopher Stewart
Computer Science & Eng

Zichen Zhang

Jenna Kline

John C. Chumley
Ohio State University

Kevyn Angueira Irrizary

Co-Leads

Digital Agriculture Hub and Use-Inspired Technologies



P. Sadayappan
University of Utah

Jinghua Yan
University of Utah

Hari Subramoni

Nawras Alnaasan

Erman Ayday
Case Western

Beth Plale
Indiana University

Alfonso Morales
University of Wisconsin

*Artificial Intelligence for
Cyberinfrastructure*

*Cyberinfrastructure for AI-Driven
Digital Agriculture*

*Privacy-aware, Explainable
AI, & Democratization*

*Stakeholder
Engagement*

The Application Domain Challenge (Digital Agriculture)

Computer Vision (CV) based classification scenarios are ubiquitous in use-inspired science domains such as Digital Agriculture

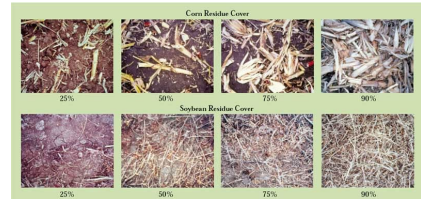

Residue Cover on Soil Surface

Residue body	Size and shape of aggregates	Water permeability and aeration	Aggregates in the soil	Aggregates after 10 days of tillage (after 1 day)	Disintegrating process	Aggregates and their stability of 1.5 m diameter
Highly porous, highly permeable, highly aeration	Highly porous, highly permeable, highly aeration	Highly porous, highly permeable, highly aeration	Highly porous, highly permeable, highly aeration	Highly porous, highly permeable, highly aeration	Highly porous, highly permeable, highly aeration	Highly porous, highly permeable, highly aeration
Highly porous, highly permeable, highly aeration	Highly porous, highly permeable, highly aeration	Highly porous, highly permeable, highly aeration	Highly porous, highly permeable, highly aeration	Highly porous, highly permeable, highly aeration	Highly porous, highly permeable, highly aeration	Highly porous, highly permeable, highly aeration
Highly porous, highly permeable, highly aeration	Highly porous, highly permeable, highly aeration	Highly porous, highly permeable, highly aeration	Highly porous, highly permeable, highly aeration	Highly porous, highly permeable, highly aeration	Highly porous, highly permeable, highly aeration	Highly porous, highly permeable, highly aeration

Soil Aggregate Size

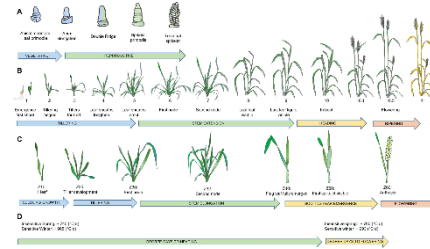

Wheat Development



Non-Uniform Emergence



Nitrogen Deficiency



European corn borer



Corn leaf aphid



Mexican bean beetle defoliation

The Data Labeling Challenge

Challenge:

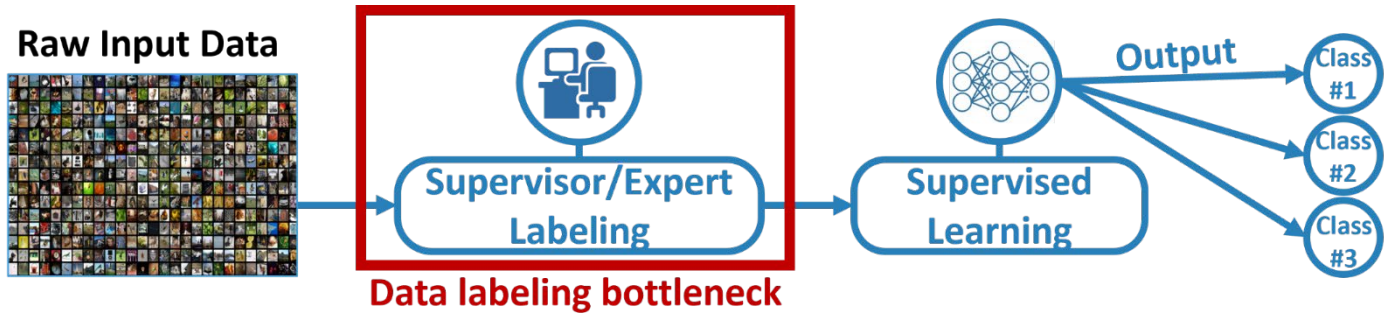

- Data samples need to be fully labeled by an expert for training and evaluation.
- Datasets may be collected frequently and in large volumes (millions of unlabeled images).
- Labeling data by experts is a significant bottleneck.
- Supervised learning can be time-consuming, costly, and infeasible for certain applications

The Computing Challenge

- Why do we need Parallel Training?
- Larger and Deeper models are being proposed
 - AlexNet -> ResNet -> NASNet – AmoebaNet -> ViT
 - DNNs require a lot of memory and a lot of computation
 - Larger models cannot fit a GPU's memory
- Single GPU training cannot keep up with ever-larger models
- Community has moved to multi-GPU training
- Multi-GPU in one node is good but there is a limit to Scale-up (8-16 GPUs)
- **Multi-node (Distributed or Parallel) Training is necessary!!**

HARVEST (High-Performance Artificial Vision Framework for Expert Labeling using Semi-Supervised Training)

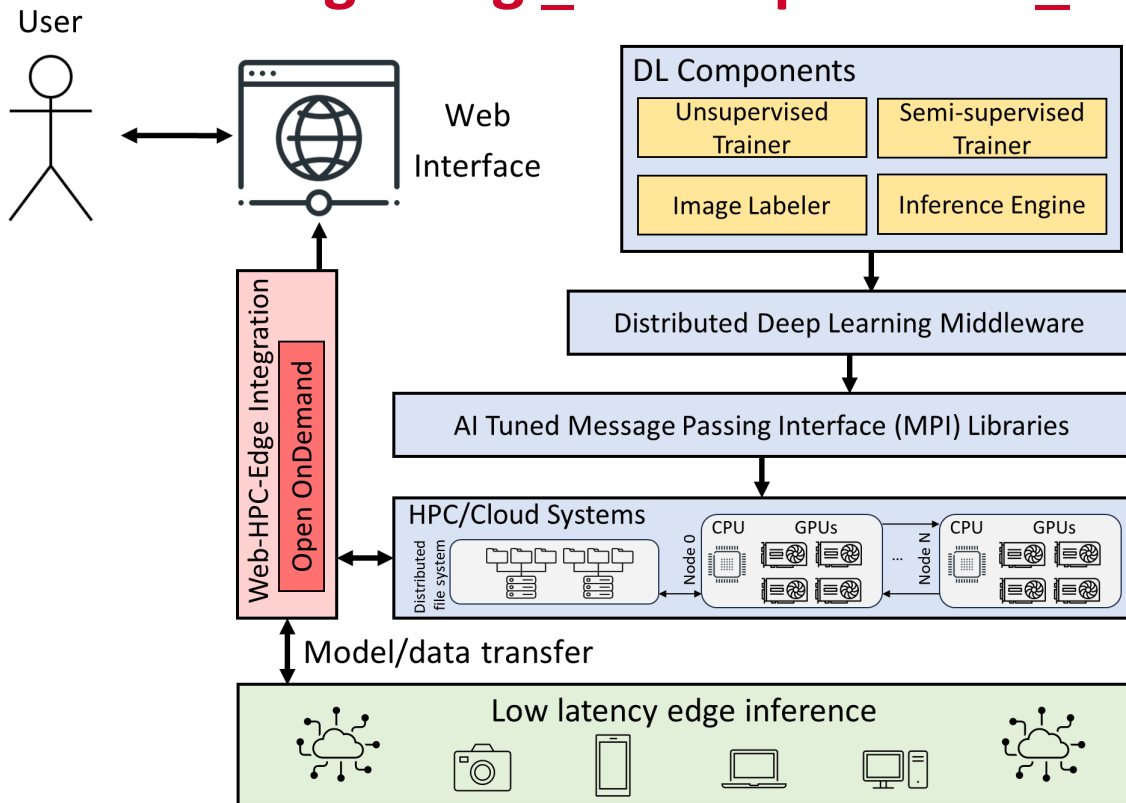

Demo: Semi-Supervised Learning

The Video is available from

<https://youtu.be/EYzAZWGvyJI>

Digital Agriculture – Crop Management

Digital Agriculture will transform crop management by:

- (1) sensing environmental conditions
- (2) characterizing crop health at fine granularities
- (3) autonomously delivering cost-effective treatments

Stakeholders include farmers and biologists—traditional agriculture professionals—**and** data scientists, machine learning experts, engineers, and HPC professionals

ICICLE seeks to develop CI needed for all stakeholders to create, share, and process agricultural data effectively and efficiently

In this context, AI will drive improvements in:

- (1) Autonomous, self-driving farms
- (2) Methods to wrangle the rapid growth of agricultural data
- (3) Data-driven and context-aware agricultural insights
- (4) Context-aware management and differential privacy
- (5) Managing open & democratized digital agriculture services

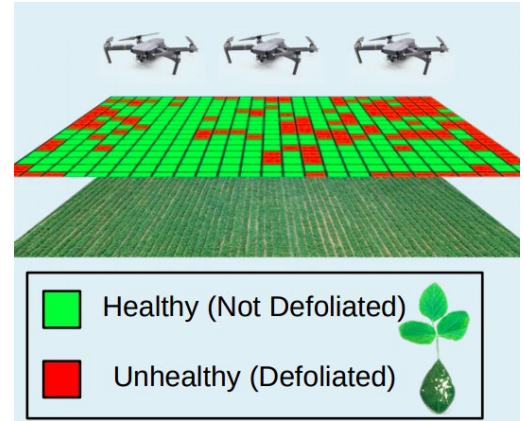

Image from Molly Caren
Agricultural Center,
OSU's 2100 -acre facility



Digital Agriculture: Aerial Crop Scouting

- **Aerial Crop Scouting:** In this workload, we seek to create *heat maps* that describe crop health for a field
 - *Inform* self-driving tractors and sprayers to reduce the application of pesticide and fertilizer
 - *Predict* crop yields for harvest and market timing
 - *Identify* trends across farms, such as the introduction of resistant weeds
- **Technology:** Unmanned aerial vehicles (UAV) capture high resolution images
 - Flying low (15 ft above ground): 1 pixel -> mm
- **Transformative:** At mm-granularity, stakeholders can detect biological phenomena invisible to satellites
 - Soybean leaf defoliation caused by Japanese beetle



Courtesy of LaRue Farms Inc.

Demo: Cloud-to-Edge Middleware

The Video is available from

<https://youtu.be/M6o0NVQXny0>

Engagement with Other Organizations

- On-going discussions with several other AI Institutes
 - AIFARMS
 - AIIRA
 - AgAID
- Collaboration with TIH-Mumbai
 - More details will be provided by Prof. Rajbabu (IIT, Mumbai)
- Interactions with industry
 - CNH Industrial
 - TCS

Smart Foodsheds

The Challenges

- Food system lacks resilience (highlighted by the pandemic)
- Food system actors are diverse, work in silos
- Access to data is difficult as is reconciling across data sources
- Need a common framework to organize, share, visualize, and deploy datasets and workflows

The Strategies

- Develop relationships between ICICLE and private partners to empower stakeholders to access, interpret, and utilize food systems processes, trends, and outcomes
- Use knowledge graphs to link domain knowledge of the environment, agriculture, food, diet, and health
- Develop PPOD, a schema that describes the attributes and relationships between **Persons, Projects, Organizations and Datasets** and instantiate it with real data from California and Ohio as a first use case.

Interactive Knowledge Learning & Environment (IKLE) for Smart Foodshed



Yamei Tu



Xiaoqi Wang



Rui Qiu



Han-Wei Shen



Patrick R Huber



Allan D Hollander

The Ohio State University

University of California Davis



Matthew Lange



Michelle Miller



Jinmeng Rao



Song Gao



Alfonso Morales

*International Center for Food Ontology
Operability Data and Semantics (IC-FOODS)*

University of Wisconsin-Madison



Christian R Garcia



Joe Stubbs

The University of Texas at Austin Texas Advanced Computing Center

Demo : Smart Foodsheds + Visual Analytics (IKLE)

The Video is available from

<https://youtu.be/WEFDcKTl3UY>

GROCERY STORE CLOSURE & COMMUNITY HEALTH

Pain points

- In public health and food systems, computer models are not used or have limited impact because decision-makers are not able to access them in a practical and timely manner.

SCENARIO



A food retail company announces plans to close a grocery store in a Columbus, Ohio neighborhood with very high % of food-insecure households.



Now the health commissioner wants to know how the grocery store closure will affect community health so they can lobby the food retail company to not close the grocery store or set up emergency food supply to reduce the impact on community health.

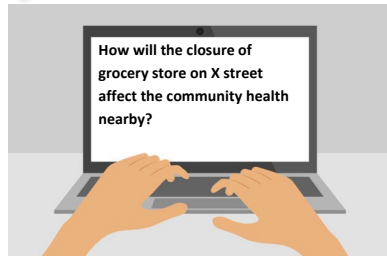

Our Solution (and use case in ICICLE)

A conversational AI-enabled web interface that allows decision-makers to run "What if?" scenarios based on an agent-based model for food insecurity.

Use Case

Objective: Help food system leaders quickly evaluate the impact of a food store closure on household food insecurity

Significance: Improving access to community-informed computational models empowers communities to use models to make better decision involving complex systems, such as the local foodshed.

Grocery Store Closure Team



***Harsh
Panday***

***Amad
Hussain***

***Erika
Goetz***

***Carlos
Guzman***

***Ayaz
Hyder***

***Huan
Sun***

***Eric
Fosler-
Lussier***

***The Ohio State University
College of Public Health / Dept. of Computer Science & Engineering***

Demo: GROCERY STORE CLOSURE & COMMUNITY HEALTH

The Video is available from

<https://youtu.be/GYjMeaE74sk>

AI4CI: HARP – HPC Application Runtime Predictor



Swathi
Vallabhajosyula



Rajiv
Ramnath



Carlos
Guzman



Joe
Stubbs

The Ohio State University
Dept. of Computer Science & Engineering

The University of Texas at Austin
Texas Advanced Computing Center

n-tasks-per-node	Walltime (mins)	Cost Per job (\$)
10	8.5954	<u>0.01719</u>
14	<u>8.5768</u>	0.01886
20	8.5852	0.02189
28	8.5931	0.02492

Cost ↓ ~30%

Goal

Estimating the resource requirements to execute an application on shared cyber infrastructures to aid recommendation systems or smart job allocations.

Accomplishments

- Understanding the allocation behavior of different users against different systems and ways for optimizing the allocations.
- Establishing an end-to-end application-independent framework called HARP (HPC Application Runtime Prediction) that can emulate the application executions, profile them, and estimate the resource requirements against targeted environments with cost/time constraints.

HARP – HPC Application Resource Predictor = Runtime

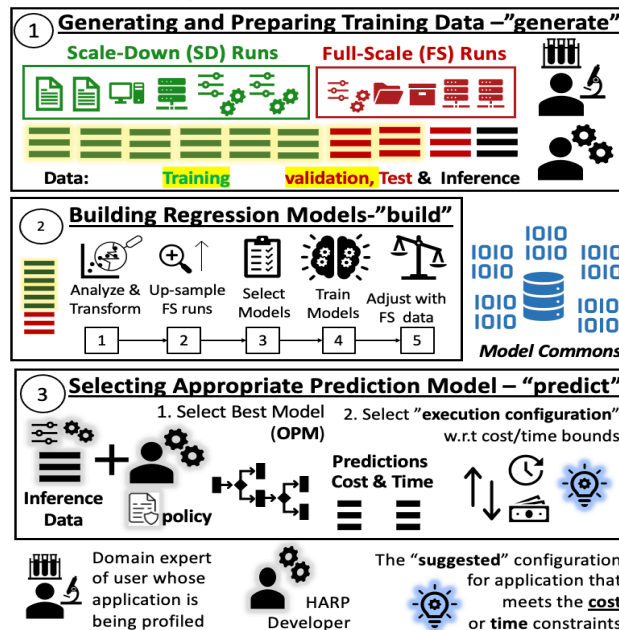

Broader Impact Backbone Network (BIBN)



Beth Plale



Maureen Biggers



Sadia Khan



Julie Wernert



Alfonso Morales

Indiana University

University of Wisconsin-Madison



Matthew Lange

*International Center for
Food Ontology OSemantics
(IC-FOODS)*



Swathi Vallabhajosyula
*ICICLE NextGens Community
Leader*

The Ohio State University



Rajiv Ramnath

San Diego Super Computing Center



Mary Thomas

Selected Accomplishments from BIBN

- BPC
 - Inclusive environments initiative: **ICICLE NextGens** group, **ICICLE Code of Conduct**
 - Building awareness: bi-weekly **Ally tips (bias)**; AI Ethics tips purposed for Indiana Univ **K-12 summer camp**
- WFD
 - **Hello ICICLE**: clients (Notebooks, command line, python, Web client) for testing software
 - Summer 2023 launch of **ICICLE AI Ethics tips** series of 6 videos
 - Consolidation and organization of **ICICLE Publication and Training Resources** (with WFD and HelloICICLE)
- KT
 - ICICLE Seminar Series
 - **Partnership Agreements** for stakeholders to engage with ICICLE. (Students, Academic Scholars, Organizations, Industry Sponsored, and Stakeholder Roundtable)
 - Engaging stakeholders, including through 2023 class of 5 **ICICLE Educational Fellows**

<https://icicle.osu.edu/knowledge-transfer/youtube-channel>

Outline

- ICICLE Vision and Goals
- Research Challenges being Addressed
- Selected Accomplishment Highlights
- **How to Get Engaged?**
- Conclusions

Multiple Levels of Collaboration and Engagement

- Using the Released Software/CI components
 - Available at <https://icicle.osu.edu/cyberinfrastructure/software>
 - Get engaged as a member in the Stakeholder Roundtable (more details below)
- Become a part of ICICLE (multiple options)
 - Student Associate
 - Visiting Research Fellow
 - Academic Collaborator
 - Industry Partner
 - Stakeholder Roundtable Member
 - More details at: <https://icicle.osu.edu/engagement/join-us>
- Join the ICICLE mailing lists (<https://icicle.osu.edu/engagement/mailling-lists>)
 - icicle-announce
 - icicle-discuss

Outline

- ICICLE Vision and Goals
- Research Challenges being Addressed
- Selected Accomplishment Highlights
- How to Get Engaged?
- **Conclusions**

Designing Next-Generation CI through Co-Designing with Use-inspired Domains

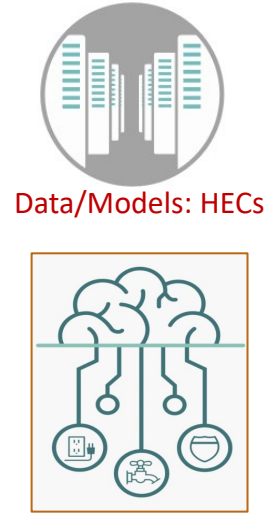
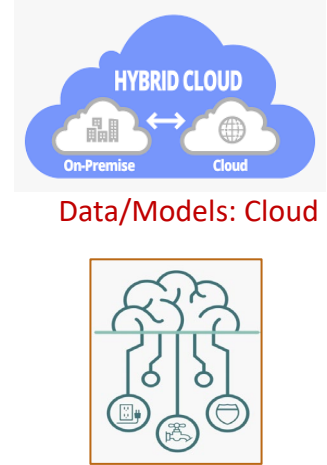
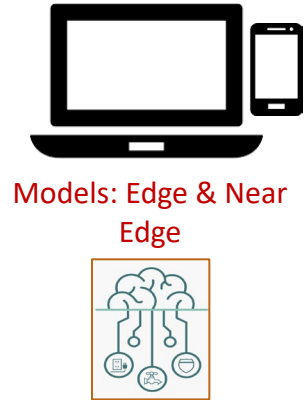

ICICLE-enabled Computing Continuum



Potential for the ICICLE Solutions to be applied to more Verticals



Smart Foodsheds



Digital Agriculture

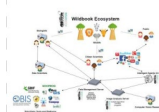

Animal Ecology



Health & Medicine



Environment



Communications & Collaboration



Mobility, Machines, & Manufacturing



AI for Social Good

ICICLE: Intelligent CyberInfrastructure with Computational Learning in the Environment

Systems AI Foundational Research for CI

Intelligent Cyber Infrastructure

CI for AI

AI for "CI for AI"



On Field Sensors



Edge & Near Edge

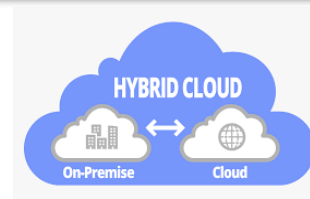

Clouds



HPC Systems & Data Centers

Emerging Computing Continuum

ICICLE Enabling Global Leadership in `Computing + AI`

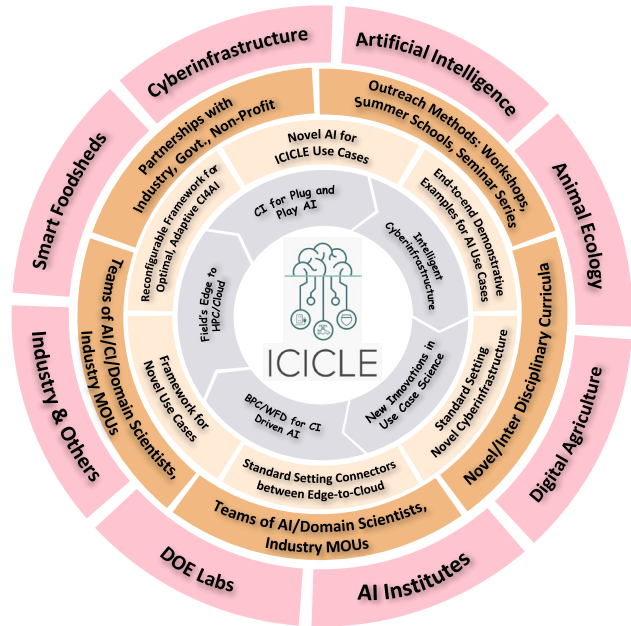

Join Us!

- Integrate into the National CI Ecosystem
- Integrative and Interoperable
- Leverages existing recognized capabilities
 - **Centers of Excellence, AI Institutes, Large Facilities**
- Collaborative
 - **Actively engaging CI experts, domain scientists,**
 - **AI/CI Users and developers**
- Sustainable and Inclusive
 - **Workforce Development, Broadening Participation, Collaboration and Knowledge Transfer**
 - **Benefits other institutes, large facilities, and all sciences beyond lifetime of award**

Acknowledgments to all ICICLE Participants (Faculty, Students and Staffs)

Current Faculty

– E. Ayday, CWRU – S. Blanas, OSU – R. Machiraju, OSU – Y. Su, OSU – A. Ahmad, Uni Stuttgart
– V. Chaudhary, CWRU – Y. Cai, OSU – DK. Panda, OSU – H. Subramoni, OSU – E. Riloff, UU
– A. Azad, IU – W. Chao, OSU – R. Ramnath, OSU – H. Sun, OSU – P. Sadayappan, UU
– P. Sharma, IU – E. Fosler-Lussier, OSU – S. Shearer, OSU – C. Stewart, RPI – E. Ely-Ledesma, UW-Madison
– H. Zhang, ISU – A. Hyder, OSU – H. Shen, OSU – B. Salimi, UCSD – S. Gao, UW-Madison
– T. Berger-Wolf, OSU – DB. Jackson-Smith, OSU – C. Stewart, OSU – R. Eigenmann, UD – A. Morales, UW-Madison

Current Staff

– M. Lange, IC-Foods – M. Abduljabbar, OSU – A. Shafi, OSU – P. Rodriguez, SDSC – A. Hollander, UC Davis
– T. Ruemping, IC-Foods – K. Armstrong, OSU – S. Khuvis, OSC – M. Tatineni, SDSC – P. Huber, UC Davis
– D. Siedband, IC-Foods – J. Chan, OSU – S. Oottikkal, OSC – R. Cardone, TACC – C. Riggle, IC-Foods
– M. Biggers, IU – J. Chumley, OSU – K. Tomko, OSC – C. Garcia, TACC – P. Hoover, UCSD
– RJ. Ping, IU – C. Guzman, OSU – D. Choi, SDSC – S. Li, TACC – M. Thomas, UCSD
– BA. Plale, IU – W. Michel, OSU – M. Kandes, SDSC – J. Stubbs, TACC – M. Miller, UW Madison
– J. Wernert, IU – N. Savardekar, OSU – A. Majumdar, SDSC – Z. Zhang, TACC

Current Ph.D. Students

– P. Kousha, OSU – C. Tu, OSU – X. Wang, OSU – Z. Zhang, OSU – J. Yan, UU
– Z. Li, OSU – Y. Tu, OSU – J. Yao, OSU – DD. Vecchia, RPI – K. Armendariz, UW-Madison
– V. Pahuja, OSU – S. Vallabhajosyula, OSU – X. Yue, OSU – M. Rosas, UD – J. Rao, UW-Madison
– R. Qiu, OSU – L. Waltz, OSU – T. Zhang, OSU – T. Jiang, UU – J. Kline, OSU
– E. Romero, OSU – B. Wang, OSU – K. Zhang, OSU – Y. Xu, UU – G. Ubbiali, IC-Foods

Current Masters Students

– R. Danhi, IC-Foods – C. Wang, OSU – S. Suresh, UW Madison
– J. Cheng, OSU – J. Yang, OSU – G. Wilkins, UW Madison
– S. Deshmukh, OSU – Q. Ding, TACC
– M. Han, OSU – V. deBella, UW Madison
– A. O'Quinn, OSU – M. Krempely, UW Madison

Current Undergraduate Students

– T. Chen, OSU – S. Shah, UT Austin
– KA. Irizarry, OSU – A. Karunakaran, UW Madison
– M. Lieber, OSU – M. Kuhn, UW Madison
– E. Luo, OSU – Y. Qu, UW Madison
– D. Venkataraman, OSU – K. Sung, UW Madison

Past Staff

– C. Campbell, IU
– S. Sanders, IU
– A. Ivanovic, OSU
– P. Rose, UCSD
– K. Pierce, TACC

Current International

Students TIH - IITB

– A. Borkar, TIH IITB
– RM. Chitre, TIH IITB
– R. Katole, TIH IITB
– S. Khandelwal, TIH IITB
– T. Sharma, TIH IITB
– A. Thaduri, TIH IITB
– S. Zac, TIH IITB

Current Institute Evaluators (WFD)

– T. McKlin, TFG
– C. Wise, TFG

Educational Fellows (2023)

– B. Alston, OSU
– TE. Feiten, UC
– A. Hingle, GMU
– C. Lucken, UC
– C. Okolo, CU

Past Faculty

– C. Hoy, OSU
– T. Tomich, UC Davis
– J. Duarte, UC San Diego
– M. Norman, UC San Diego

Current International

Faculty TIH – IITB

– M. Baghini, IITB
– Chalapathi G, IITB
– A. Sinha, IITB
– R. Velmurugan, IITB
– S. Paramane, TIH IITB

Current K-12 Students

– R. Estanislao, SDSC
– D. Lee, SDSC
– M. Ray, SDSC
– S. Samar, SDSC

Past K-12 Students

– J. Karpinski, SDSC
– A. Sarin, SDSC

Past Ph.D. Students

– FB Saravi, CWRU
– MK. Rahman, IU
– T. Zhang, ISU
– H. Ahn, OSU
– P. Chawla, OSU
– E. Goetz, OSU
– Y. Gu, OSU

– A. Jain, OSU
– D. Suresh, OSU
– S. Rajee, UU
– H. Park, UW Madison

Past Masters Students

– SR. Kalli, OSU
– H. Panday, OSU
– RR. Loka, UW Madison
– D. Sykes, UW Madison

Past UG Students

– S. Ockerman, OSU
– KP. Sailaja, OSU
– C. Washington, OSU
– J. Kim, TACC
– C. Skevofilax, TACC
– S. Wegner, UW Madison

Thank You!